

头顶花洒，淋浴套件，淋浴-杆

技术说明书



花洒和花洒臂	页.634
手持花洒	页.651
淋浴滑杆	页.658
取水栓	页.660
软管	页.661
花洒托架	页.663
侧边身体喷雾	页.664

ACQUA ZONE系列

多功能花洒 - DREAM



C031
DREAM带灯光效果
53 x 53cm
漆面: 13, 29, 95,
P5, P6, P9, 01 - **38, 93**

多功能花洒



C032
53 x 53cm
漆面: 13, 29, 95,
P5, P6, P9, 01 - **38, 93**

ACQUAFIT系列

多功能花洒 - 多功能花洒

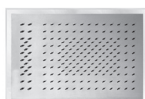

K021
DREAM带灯光效果
边框: 50 x 35cm
淋浴花洒: 45 x 30cm
漆面: 13, 29, 95, P5, P6,
P9, S1, 01 - **38, 93**



K022
边框: 50 x 35cm
淋浴花洒: 45 x 30cm
漆面: 13, 29, 95, P5,
P6, P9, S1, 01 - **38, 93**



K031B+K031A
DREAM带灯光效果
淋浴花洒: 45 x 30cm
漆面: 13, 29, 95, P5,
P6, P9, S1, 01 - **38, 93**



K032B+K031A
淋浴花洒: 45 x 30cm
漆面: 13, 29, 95, P5,
P6, P9, S1, 01 - **38, 93**

多功能花洒 - 多功能花洒

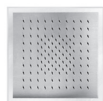

K001
DREAM带灯光效果
边框: 35 x 35cm
淋浴花洒: 30 x 30cm
漆面: 13, 29, 95, P5,
P6, P9, S1, Q7, Q8,
01 - **38, 93**

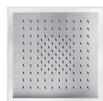

K002
边框: 35 x 35cm
淋浴花洒: 30 x 30cm
漆面: 13, 29, 95, P5,
P6, P9, S1, Q7, Q8, 01
- **38, 93**



K041B+K031A
DREAM带灯光效果
淋浴花洒: 30 x 30cm
漆面: 13, 29, 95, P5,
P6, P9, S1, 01 - **38, 93**



K042B+K031A
淋浴花洒: 30 x 30cm
漆面: 13, 29, 95, P5,
P6, P9, S1, 01 - **38, 93**



K052
淋浴花洒: 30 x 30cm
漆面: 13, 29, 95, P5,
P6, P9, S1, Q7, Q8, 01
- **38, 93**



K053
淋浴花洒: 30 x 30cm
漆面: 13, 29, 95, P5,
P6, P9, S1, Q7, Q8,
01 - **38, 93**

多功能花洒 - 多功能花洒



K061
DREAM带灯光效果
边框: Ø 35cm
淋浴花洒: Ø 30cm
漆面: 13, 29, 95, P5,
P6, P9, S1, Q7, Q8, 01
- **38, 93**



K062
边框: Ø 35cm
淋浴花洒: Ø 30cm
漆面: 13, 29, 95, P5,
P6, P9, S1, Q7, Q8, 01
- **38, 93**



K072
淋浴花洒: Ø 30cm
漆面: 13, 29, 95, P5,
P6, P9, S1, Q7, Q8, 01
- **38, 93**



K073
淋浴花洒: Ø 30cm
漆面: 13, 29, 95, P5,
P6, P9, S1, Q7, Q8, 01
- **38, 93**

MILANOSLIM系列

淋浴柱



H001
MILANOSLIM系列
漆面: 38, 93



H121
MILANOSLIM OUTDOOR.1系列
漆面: 93

头顶花洒

双头花洒



8035B+8035A
漆面: 02, 95, P5, P6, P9, S1, Q7, Q8, 01 - 93

雨式花洒



8036B+8036A
漆面: 02, 95, P5, P6, P9, S1, Q7, Q8, 01 - 93

瀑布式花洒



8043B+8036A
漆面: 02, P5, P6, S1, Q7, Q8, 01 - 93



6701B+6701A - ALA 系列
漆面: 02, 13, P5 - 93

雨式花洒



8095
Ø 20cm
漆面: 02



8136
Ø 20cm
漆面: 02, 13, 29, P5, P6, P9, S1, Q7, Q8, 06/02 - 93



9230
Ø 20cm
漆面: 02, 13, 29, 06



8083
Ø 24cm
漆面: 02, 13, 29, 95, P5, P6, P9, S1, Q7, Q8, 01 - 93



8142
Ø 24cm
漆面: 02, 13, 29, 95, P5, P6, P9, S1, 01



8146
Ø 25cm
漆面: 02, 13, 29, 95, P5, P6, P9, S1, 01 - 93



8084
Ø 36cm
漆面: 02 - 93



8008
20x20cm
漆面: 02, 13, P5, P6, P9, S1



8104
30x30cm
漆面: 02



L011B+L003A
ACQUADOLCE系列
42,1 x 65,1cm
漆面: 38, 93



8141
O-XY系列
45 x 8,5cm
漆面: 95, P5 - 93

花洒臂



8027 - 8137 - 8028
30cm - 35cm - 45cm
漆面: 02, 13, 29, 95, P5, P6, P9, S1, Q7, Q8, 01, 06/02 - 93



8107 - 8108
30cm - 45cm
漆面: 02, 13, 29, P5, P6, P9, S1 - 93



9231 - 8011
30cm - 45cm
漆面: 02, 13, 29, 95, P5, P6, P9, S1, 01 - 93



8038 - 8039
30cm - 45cm
漆面: 02, 13, 29, P5, P6, P9, S1 - 93



8081
41cm
漆面: 02 - 93



9236 - 9237
25cm - 45cm
漆面: 02, 13, 29, 95, P5, P6, P9, S1, Q7, Q8, 01, 06/02 - 93



8040 - 8041
25cm - 45cm
漆面: 02, 13, 29, P5, P6, P9, S1 - 93

38 - 不锈钢抛光色 _ 93 - 不锈钢拉丝

手持花洒套件



8051
SUN款手持花洒
漆面: 02, 13, 29



8105
SUN款手持花洒
漆面: 02, 13, 29



8052
SUN / FIT款手持花洒
漆面: 02, 95, P5, P6, P9, S1, Q7, Q8 - 93



8093
FIT款手持花洒
漆面: 02, 13, 29, 95, P5, P6, P9, S1, Q7, Q8 - 93



8116
FIT款手持花洒
漆面: 02, 13, 29, P5, P6, P9, S1 - 93



8021
SOHO款手持花洒
漆面: 02, 13



8068
FIT款手持花洒
漆面: 02, 13, P5, P6, P9, S1 - 93



R043
ICONA款手持花洒
漆面: 02, 13, 95, P5, P6, P9, S1, Q7, Q8



5943
VENEZIA款手持花洒
漆面: 02, 95, P5, P6, P9, 01



5944
FIT款手持花洒
漆面: 02, 95, P5, P6, P9, 01



8144
FIT款手持花洒
漆面: 95, P5 - 93

手持花洒



9673
SUN
漆面: 02, 13, 29



8783
FIT
漆面: 02, 13, 29, 95, P5, P6, P9, S1, Q7, Q8, 01, 06 - 93



9418
SOHO
漆面: 02, 13



9849
VENEZIA
漆面: 02, 95, P5, P6, P9, 01



8914
disco: Ø 10cm
漆面: 02



Z348
disco: Ø 11cm
3 getti
漆面: 02, 13, 92, 95, P5, P6, P9, S1



8929
disco: Ø 14cm
3 getti
漆面: 02, 13, 92, P5, P6, P9, S1



8938
ICONA
漆面: 02, 13, 95, P5, P6, P9, S1, Q7, Q8



9890
disco: Ø 14cm
3 getti
漆面: 02

侧边身体按摩喷雾



9248
漆面: 02, 13, 29, 95, P5, P6, P9, S1, 01



8024
漆面: 02, 13, P5, P6, P9, S1



8055
漆面: 02



8056
漆面: 02



8034B+8034A
漆面: 02, 95, P5, P6, P9, S1, Q7, Q8 - 93

取水栓 / 手持花洒支架

取水栓



9323
漆面: 02, 13, 29, 95, P5, P6, P9, S1, Q7, Q8 - 93



9446
漆面: 02, 13, 95, P5, P6, P9, S1, Q7, Q8 - 93



7034
漆面: 02, 13, 29, 95, P5, P6, P9, S1, Q7, Q8 - 93



9417
漆面: 02, 13, 29, 95, P5, P6, P9, S1, Q7, Q8 - 93

手持花洒固定托架



9129
漆面: 02, 13, 29 - 93



Q133
漆面: 02, 13, 29, P5, P6, P9, S1, Q7, Q8



0992
漆面: 02

手持花洒固定托架

淋浴滑杆

淋浴滑杆



8016
漆面: 02, 01 - 93



8096
漆面: 02



8145
漆面: 02, 13, 29, 95, P5, P6, P9, Q7, Q8, S1, 01 - 93



9247
漆面: 02, 13, 29, P5, P6, P9, S1, 01 - 93

38 - 不锈钢抛光色 _ 93 - 不锈钢拉丝

双头花洒

- 雨式
- 瀑布式
- 基材：黄铜
- 基材：不锈钢
- 墙面装
- 流速限制器17升/分钟 3 bar
- 防钙化系统
- 1/2" 寸入水管
- 最小流速 12升/分钟

注意：保证产品正确运行的必要条件：水流量不小于：12升/分钟

8035B

外部组件

铬色	86 02 8035B
Polished Nickel PVD	86 95 8035B
Matt Gun Metal PVD	86 P5 8035B
Matt British Gold PVD	86 P6 8035B
Matt Copper PVD	86 P9 8035B
Deep Black PVD	86 S1 8035B
Pure Brass PVD	86 Q7 8035B
Raw Metal PVD	86 Q8 8035B
超金色	86 01 8035B

不锈钢拉丝

86 93 8035B

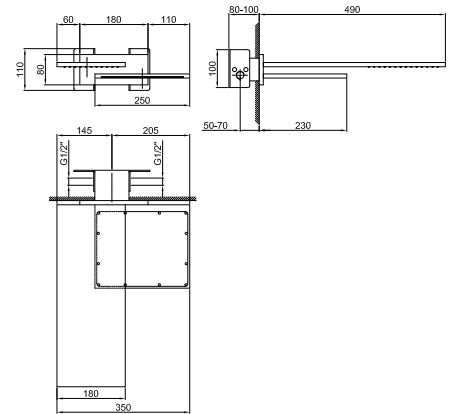

8035A

墙内预埋组件

86 00 8035A



花洒和花洒臂

雨式花洒

- 基材：黄铜
- 基材：不锈钢
- 墙面装
- 流速限制器17升/分钟 3 bar
- 防钙化系统
- 1/2" 寸入水管
- 最小流速 10升/分钟

注意：保证产品正确运行的必要条件 水流量不小于：10升/分钟

8036B

外部组件

铬色	86 02 8036B
Polished Nickel PVD	86 95 8036B
Matt Gun Metal PVD	86 P5 8036B
Matt British Gold PVD	86 P6 8036B
Matt Copper PVD	86 P9 8036B
Deep Black PVD	86 S1 8036B
Pure Brass PVD	86 Q7 8036B
Raw Metal PVD	86 Q8 8036B
超金色	86 01 8036B

不锈钢拉丝 **86 93 8036B**



8036A

墙内预埋组件

86 00 8036A

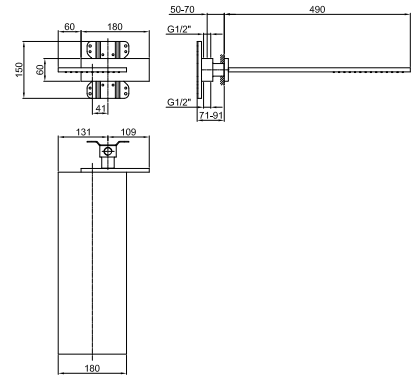

瀑布式花洒

- 基材：黄铜
- 基材：不锈钢
- 墙面装
- 流速限制器17升/分钟 3 bar
- 1/2" 寸入水管
- 最小流速 12升/分钟

注意：保证产品正确运行的必要条件：水流量不小于：12升/分钟

8043B

外部组件

铬色	86 02 8043B
Matt Gun Metal PVD	86 P5 8043B
Matt British Gold PVD	86 P6 8043B
Matt Copper PVD	86 P9 8043B
Deep Black PVD	86 S1 8043B
Pure Brass PVD	86 Q7 8043B
Raw Metal PVD	86 Q8 8043B
超金色	86 01 8043B

不锈钢拉丝

86 93 8043B

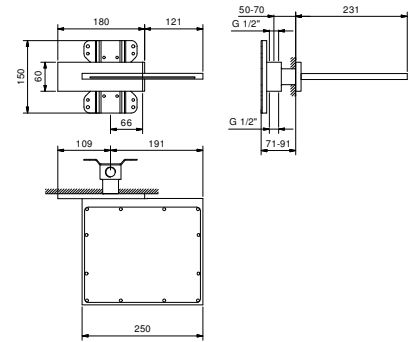

8036A

墙内预埋组件

86 00 8036A



花洒和花洒臂

瀑布式花洒

- ALA系列
- 基材：不锈钢
- PARAPAN® 斜面出水
- 墙面装
- 1/2" 寸入水管
- 适用于淋浴

注意：保证产品正确运行的必要条件：水流量不小于：10升/分钟

6701B

外部组件

铬色 82 02 6701B
 哑光黑 82 13 6701B
 Matt Gun Metal PVD 82 P5 6701B

不锈钢拉丝 82 93 6701B

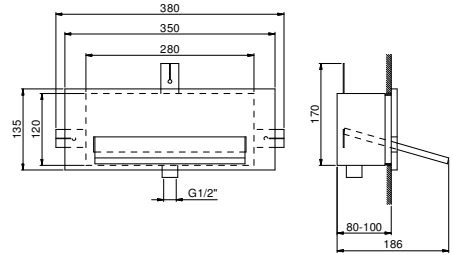

6701A

墙内预埋组件

82 00 6701A



8141

雨式花洒

- 基材：不锈钢
- 墙面装
- 转动的
- 防钙化系统
- 1/2" 寸入水管



Polished Nickel PVD 49 95 8141
 Matt Gun Metal PVD 49 P5 8141

不锈钢拉丝 49 93 8141

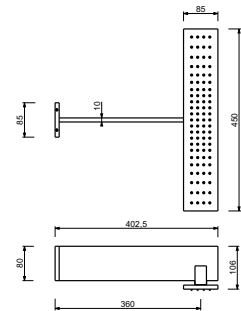

8095

雨式花洒

- 直径20cm
- 基材：ABS
- 流速限制器12升/分钟 3 bar
- 防钙化系统
- 1/2" 寸入水管
- 止回阀

注意：保证产品正确运行的必要条件 水流量不小于：10升/分钟

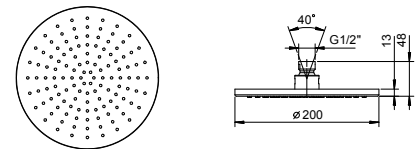

铬色 86 02 8095

花洒和花洒臂

8136

雨式花洒

- 直径20cm
- 基材：黄铜
- 基材：不锈钢
- 流速限制器12升/分钟 3 bar
- 防钙化系统
- 1/2" 寸入水管
- 止回阀

注意：保证产品正确运行的必要条件 水流量不小于：10升/分钟

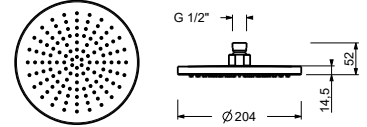

铬色	86 02 8136
哑光黑	86 13 8136
哑光白色	86 29 8136
Polished Nickel PVD	86 95 8136
Matt Gun Metal PVD	86 P5 8136
Matt British Gold PVD	86 P6 8136
Matt Copper PVD	86 P9 8136
Deep Black PVD	86 S1 8136
Pure Brass PVD	86 Q7 8136
Raw Metal PVD	86 Q8 8136
红色	86 06 8136
定制RAL颜色	86 _ 8136

不锈钢拉丝 86 93 8136

9230

雨式花洒

- 直径20cm
- 基材：黄铜
- 流速限制器12升/分钟 3 bar
- 防钙化系统
- 1/2" 寸入水管
- 止回阀

注意：保证产品正确运行的必要条件 水流量不小于：10升/分钟

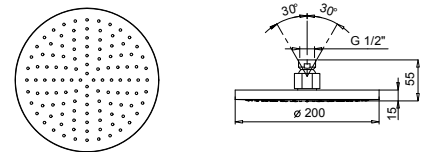

铬色	86 02 9230
哑光黑	86 13 9230
哑光白色	86 29 9230
红色	86 06 9230

花洒和花洒臂

8083

雨式花洒

- 直径24cm
- 基材：不锈钢
- 流速限制器12升/分钟 3 bar
- 防钙化系统
- 1/2" 寸入水管
- 止回阀

注意：保证产品正确运行的必要条件 水流量不小于：10升/分钟

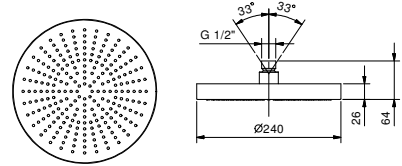
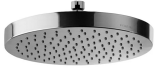

铬色	86 02 8083
哑光黑	86 13 8083
哑光白色	86 29 8083
Polished Nickel PVD	86 95 8083
Matt Gun Metal PVD	86 P5 8083
Matt British Gold PVD	86 P6 8083
Matt Copper PVD	86 P9 8083
Deep Black PVD	86 S1 8083
Pure Brass PVD	86 Q7 8083
Raw Metal PVD	86 Q8 8083
超金色	86 01 8083

不锈钢拉丝 **86 93 8083**

8142

雨式花洒

- 直径24cm
- 基材：ABS
- 流速限制器12升/分钟 3 bar
- 防钙化系统
- 1/2" 寸入水管
- 止回阀

注意：保证产品正确运行的必要条件 水流量不小于：10升/分钟

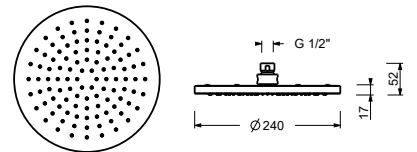

铬色	86 02 8142
哑光黑	86 13 8142
哑光白色	86 29 8142
Polished Nickel PVD	86 95 8142
Matt Gun Metal PVD	86 P5 8142
Matt British Gold PVD	86 P6 8142
Matt Copper PVD	86 P9 8142
Deep Black PVD	86 S1 8142
超金色	86 01 8142

花洒和花洒臂

8146

雨式花洒

- 直径25cm
- 基材：不锈钢
- 流速限制器12升/分钟 3 bar
- 防钙化系统
- 1/2" 寸入水管
- 止回阀

注意：保证产品正确运行的必要条件 水流量不小于：10升/分钟

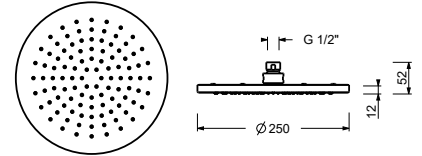

铬色	86 02 8146
哑光黑	86 13 8146
哑光白色	86 29 8146
Polished Nickel PVD	86 95 8146
Matt Gun Metal PVD	86 P5 8146
Matt British Gold PVD	86 P6 8146
Matt Copper PVD	86 P9 8146
Deep Black PVD	86 S1 8146
超金色	86 01 8146

不锈钢拉丝 **86 93 8146**

K073

雨式花洒

- ACQUAFIT
- 水功能：
- 第一个功能：240 个防水垢喷嘴
- 直径30cm
- 基材：不锈钢
- 止回阀
- 流速限制器 14升/分钟 3 bar
- 防钙化系统
- 1/2" 寸入水管

注意：保证产品正确运行的必要条件：水流量不小于：12升/分钟

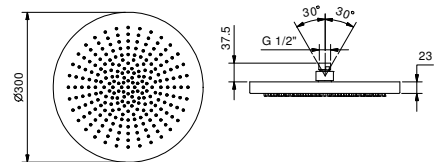

不锈钢抛光色	79 38 K073
哑光黑	79 13 K073
哑光白色	79 29 K073
Polished Nickel PVD	79 95 K073
Matt Gun Metal PVD	79 P5 K073
Matt British Gold PVD	79 P6 K073
Matt Copper PVD	79 P9 K073
Deep Black PVD	79 S1 K073
Pure Brass PVD	79 Q7 K073
Raw Metal PVD	79 Q8 K073
超金色	79 01 K073

不锈钢拉丝 **79 93 K073**

花洒和花洒臂

8084

雨式花洒

- 直径36cm
- 基材：不锈钢
- 防钙化系统
- 1/2" 寸入水管
- 止回阀

注意：保证产品正确运行的必要条件：
水流量不小于：15升/分钟

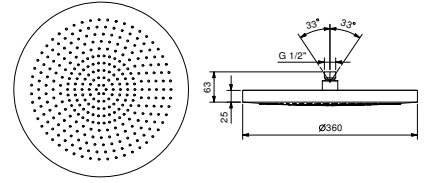

铬色 86 02 8084

不锈钢拉丝 86 93 8084

8008

雨式花洒

- 20x20cm
- 基材：黄铜
- 流速限制器12升/分钟 3 bar
- 防钙化系统
- 1/2" 寸入水管
- 止回阀

注意：保证产品正确运行的必要条件 水流量不小于：10升/分钟

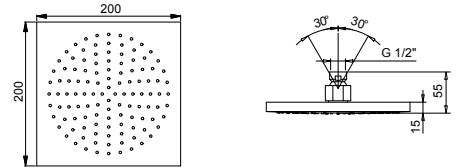

铬色 86 02 8008

哑光黑 86 13 8008

Matt Gun Metal PVD 86 P5 8008

Matt British Gold PVD 86 P6 8008

Matt Copper PVD 86 P9 8008

Deep Black PVD 86 S1 8008

花洒和花洒臂

8104

雨式花洒

- 30x30cm
- 基材：ABS
- 流速限制器12升/分钟 3 bar
- 防钙化系统
- 1/2" 寸入水管
- 止回阀

注意：保证产品正确运行的必要条件 水流量不小于：10升/分钟

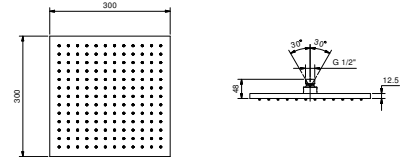

铬色

86 02 8104

K053

多功能花洒

- ACQUAFIT
- 水功能：
- 第一个功能：125 个防水垢喷嘴
- 30x30cm
- 基材：不锈钢
- 止回阀
- 流速限制器12升/分钟 3 bar

注意：保证产品正确运行的必要条件：水流量不小于：9升/分钟

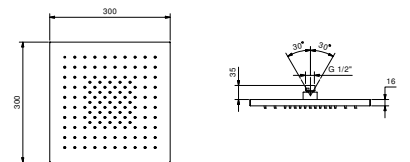
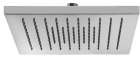

- | | |
|-----------------------|------------|
| 不锈钢抛光色 | 79 38 K053 |
| 哑光黑 | 79 13 K053 |
| 哑光白色 | 79 29 K053 |
| Matt Gun Metal PVD | 79 P5 K053 |
| Matt British Gold PVD | 79 P6 K053 |
| Matt Copper PVD | 79 P9 K053 |
| Deep Black PVD | 79 S1 K053 |
| Pure Brass PVD | 79 Q7 K053 |
| Raw Metal PVD | 79 Q8 K053 |
| 超金色 | 79 01 K053 |

不锈钢拉丝 79 93 K053

花洒和花洒臂

多功能花洒

- ACQUADOLCE
- 水功能：
- 第一个功能：168 个防水垢喷嘴-雨淋式
- 第二个功能：雨雾式 - 1个带防滴阀的防水垢喷嘴
- 421 x 651,5 mm
- 墙面装

注意：正确运行的必要条件：最低水流量：12升 / 分钟

L011B



外部组件

不锈钢抛光色 69 38 L011B

不锈钢拉丝 69 93 L011B

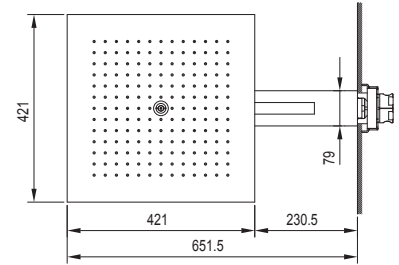

L003A



墙内预埋组件

69 00 L003A

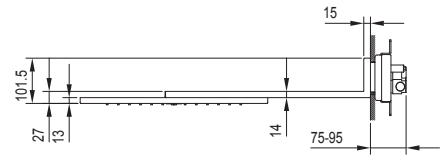

8027

花洒臂

- 长度30cm
- 圆形底座
- 墙面装
- 1/2" 寸入水管



- | | |
|-----------------------|------------|
| 铬色 | 86 02 8027 |
| 哑光黑 | 86 13 8027 |
| 哑光白色 | 86 29 8027 |
| Polished Nickel PVD | 86 95 8027 |
| Matt Gun Metal PVD | 86 P5 8027 |
| Matt British Gold PVD | 86 P6 8027 |
| Matt Copper PVD | 86 P9 8027 |
| Deep Black PVD | 86 S1 8027 |
| Pure Brass PVD | 86 Q7 8027 |
| Raw Metal PVD | 86 Q8 8027 |
| 超金色 | 86 01 8027 |
| 红色 | 86 06 8027 |

不锈钢拉丝 86 93 8027

选配: 适用石膏板的预埋件

W046 91 00 W046

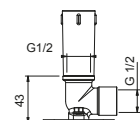
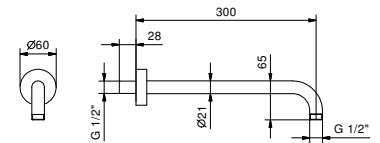

花洒和花洒臂

8137

花洒臂

- 长度35cm
- 圆形底座
- 墙面装
- 1/2" 寸入水管



铬色	86 02 8137
哑光黑	86 13 8137
哑光白色	86 29 8137
Polished Nickel PVD	86 95 8137
Matt Gun Metal PVD	86 P5 8137
Matt British Gold PVD	86 P6 8137
Deep Black PVD	86 S1 8137
Pure Brass PVD	86 Q7 8137
Raw Metal PVD	86 Q8 8137
超金色	86 01 8137
红色	86 06 8137

不锈钢拉丝 **86 93 8137**

选配: 适用石膏板的预埋件

W046 91 00 W046

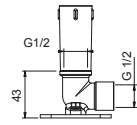
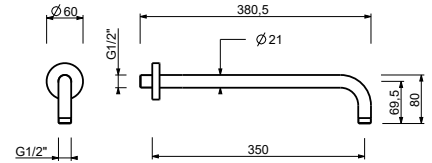

8028

花洒臂

- 长度45cm
- 圆形底座
- 墙面装
- 1/2" 寸入水管



铬色	86 02 8028
哑光黑	86 13 8028
哑光白色	86 29 8028
Polished Nickel PVD	86 95 8028
Matt Gun Metal PVD	86 P5 8028
Matt British Gold PVD	86 P6 8028
Matt Copper PVD	86 P9 8028
Deep Black PVD	86 S1 8028
Pure Brass PVD	86 Q7 8028
Raw Metal PVD	86 Q8 8028
超金色	86 01 8028
红色	86 06 8028

不锈钢拉丝 **86 93 8028**

选配: 适用石膏板的预埋件

W046 91 00 W046

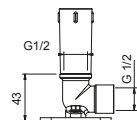
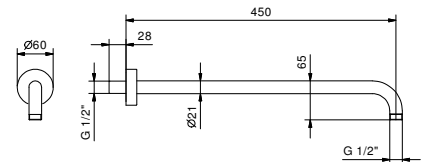

花洒和花洒臂

8107

花洒臂

- 长度30cm
- 方形底块
- 墙面装
- 1/2" 寸入水管



铬色	86 02 8107
哑光黑	86 13 8107
哑光白色	86 29 8107
Matt Gun Metal PVD	86 P5 8107
Matt British Gold PVD	86 P6 8107
Matt Copper PVD	86 P9 8107
Deep Black PVD	86 S1 8107

不锈钢拉丝 **86 93 8107**

选配: 适用石膏板的预埋件

W046 91 00 W046

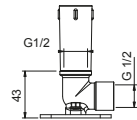
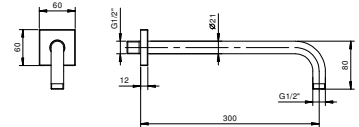

8108

花洒臂

- 长度45cm
- 方形底块
- 墙面装
- 1/2" 寸入水管



铬色	86 02 8108
哑光黑	86 13 8108
哑光白色	86 29 8108
Matt Gun Metal PVD	86 P5 8108
Matt British Gold PVD	86 P6 8108
Matt Copper PVD	86 P9 8108
Deep Black PVD	86 S1 8108

不锈钢拉丝 **86 93 8108**

选配: 适用石膏板的预埋件

W046 91 00 W046

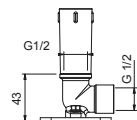
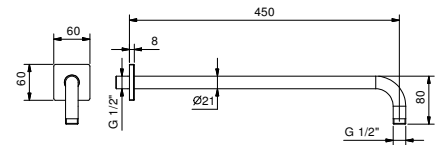

花洒和花洒臂

9231

花洒臂

- 长度30cm
- 圆形底座
- 墙面装
- 1/2" 寸入水管



铬色	86 02 9231
哑光黑	86 13 9231
哑光白色	86 29 9231
Polished Nickel PVD	86 95 9231
Matt Gun Metal PVD	86 P5 9231
Matt British Gold PVD	86 P6 9231
Matt Copper PVD	86 P9 9231
Deep Black PVD	86 S1 9231
超金色	86 01 9231

不锈钢拉丝 **86 93 9231**

选配: 适用石膏板的预埋件

W046 91 00 W046

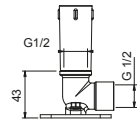
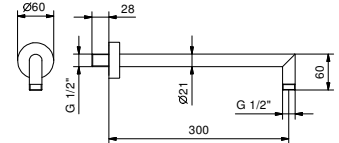

8011

花洒臂

- 长度45cm
- 圆形底座
- 墙面装
- 1/2" 寸入水管



铬色	86 02 8011
哑光黑	86 13 8011
哑光白色	86 29 8011
Polished Nickel PVD	86 95 8011
Matt Gun Metal PVD	86 P5 8011
Matt British Gold PVD	86 P6 8011
Matt Copper PVD	86 P9 8011
Deep Black PVD	86 S1 8011
超金色	86 01 8011

不锈钢拉丝 **86 93 8011**

选配: 适用石膏板的预埋件

W046 91 00 W046

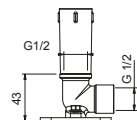
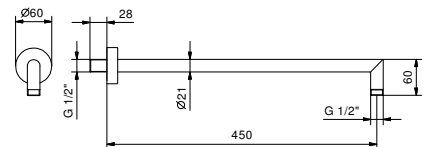

花洒和花洒臂

8038

花洒臂

- 长度30cm
- 方形底块
- 墙面装
- 1/2" 寸入水管



铬色	86 02 8038
哑光黑	86 13 8038
哑光白色	86 29 8038
Polished Nickel PVD	86 95 8038
Matt Gun Metal PVD	86 P5 8038
Matt British Gold PVD	86 P6 8038
Matt Copper PVD	86 P9 8038
Deep Black PVD	86 S1 8038

不锈钢拉丝 **86 93 8038**

选配: 适用石膏板的预埋件

W046 91 00 W046

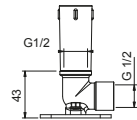
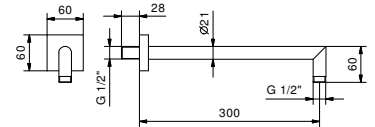

8039

花洒臂

- 长度45cm
- 方形底块
- 墙面装
- 1/2" 寸入水管



铬色	86 02 8039
哑光黑	86 13 8039
哑光白色	86 29 8039
Polished Nickel PVD	86 95 8039
Matt Gun Metal PVD	86 P5 8039
Matt British Gold PVD	86 P6 8039
Matt Copper PVD	86 P9 8039
Deep Black PVD	86 S1 8039

不锈钢拉丝 **86 93 8039**

选配: 适用石膏板的预埋件

W046 91 00 W046

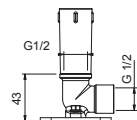
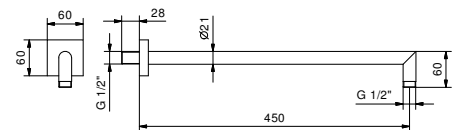

花洒和花洒臂

8081

花洒臂

- 长度40cm
- 长方形底块
- 墙面装
- 1/2" 寸入水管

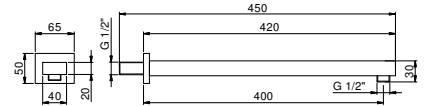

铬色 86 02 8081

不锈钢拉丝 86 93 8081

选配: 适用石膏板的预埋件

W046 91 00 W046

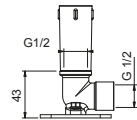

9236

花洒臂

- 长度25cm
- 圆形底座
- 天花板吊顶安装
- 1/2" 寸入水管



- | | |
|-----------------------|------------|
| 铬色 | 86 02 9236 |
| 哑光黑 | 86 13 9236 |
| 哑光白色 | 86 29 9236 |
| Polished Nickel PVD | 86 95 9236 |
| Matt Gun Metal PVD | 86 P5 9236 |
| Matt British Gold PVD | 86 P6 9236 |
| Matt Copper PVD | 86 P9 9236 |
| Deep Black PVD | 86 S1 9236 |
| Pure Brass PVD | 86 Q7 9236 |
| Raw Metal PVD | 86 Q8 9236 |
| 超金色 | 86 01 9236 |
| 红色 | 86 06 9236 |

不锈钢拉丝 86 93 9236

选配: 适用石膏板的预埋件

W046 91 00 W046

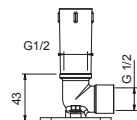
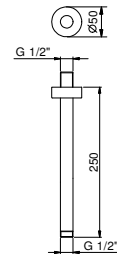

花洒和花洒臂

9237

花洒臂

- 长度45cm
- 圆形底座
- 天花板吊顶安装
- 1/2" 寸入水管



铬色	86 02 9237
哑光黑	86 13 9237
哑光白色	86 29 9237
Polished Nickel PVD	86 95 9237
Matt Gun Metal PVD	86 P5 9237
Matt British Gold PVD	86 P6 9237
Matt Copper PVD	86 P9 9237
Deep Black PVD	86 S1 9237
Pure Brass PVD	86 Q7 9237
Raw Metal PVD	86 Q8 9237
超金色	86 01 9237
红色	86 06 9237

不锈钢拉丝 **86 93 9237**

选配: 适用石膏板的预埋件

W046 91 00 W046

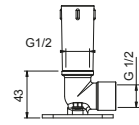
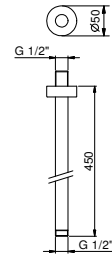

8040

花洒臂

- 长度25cm
- 方形底座
- 天花板吊顶安装
- 1/2" 寸入水管



铬色	86 02 8040
哑光黑	86 13 8040
Polished Nickel PVD	86 95 8040
Matt Gun Metal PVD	86 P5 8040
Matt British Gold PVD	86 P6 8040
Matt Copper PVD	86 P9 8040
Deep Black PVD	86 S1 8040

不锈钢拉丝 **86 93 8040**

选配: 适用石膏板的预埋件

W046 91 00 W046

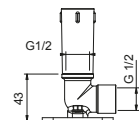
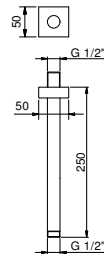

花洒和花洒臂

8041

花洒臂

- 长度45cm
- 方形底座
- 天花板吊顶安装
- 1/2" 寸入水管

铬色	86 02 8041
哑光黑	86 13 8041
Polished Nickel PVD	86 95 8041
Matt Gun Metal PVD	86 P5 8041
Matt British Gold PVD	86 P6 8041
Matt Copper PVD	86 P9 8041
Deep Black PVD	86 S1 8041

不锈钢拉丝 **86 93 8041**

选配: 适用石膏板的预埋件

W046 91 00 W046

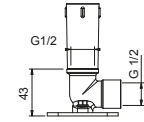
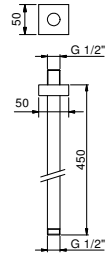

手持花洒

8051

整套淋浴

- SUN系列手持花洒
- 带手持花洒托架的取水栓
- 圆形底座
- 150cm PVC软管
- 1/2" 寸入水管

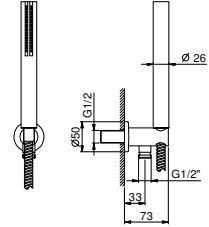

铬色	86 02 8051
哑光黑	86 13 8051
哑光白色	86 29 8051

8105

整套淋浴

- SUN系列手持花洒
- 带手持花洒托架的取水栓
- 方形底块
- 150cm PVC软管
- 1/2" 寸入水管

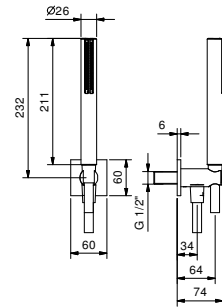

铬色	86 02 8105
哑光黑	86 13 8105
哑光白色	86 29 8105

8052

整套淋浴

- SUN系列手持花洒
- 带手持花洒托架的取水栓
- 方形底块
- 150cm PVC软管
- 1/2" 寸入水管

“备注：FIT系列手持花洒适用于PVD和93 漆面/材质”

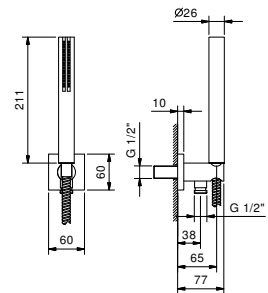

铬色	86 02 8052
Polished Nickel PVD	86 95 8052
Matt Gun Metal PVD	86 P5 8052
Matt British Gold PVD	86 P6 8052
Matt Copper PVD	86 P9 8052
Deep Black PVD	86 S1 8052
Pure Brass PVD	86 Q7 8052
Raw Metal PVD	86 Q8 8052

不锈钢拉丝 86 93 8052

手持花洒

8093

整套淋浴

- FIT系列手持花洒
- 带手持花洒托架的取水栓
- 圆形底座
- 150cm PVC软管
- 1/2" 寸入水管



铬色	86 02 8093
哑光黑	86 13 8093
哑光白色	86 29 8093
Polished Nickel PVD	86 95 8093
Matt Gun Metal PVD	86 P5 8093
Matt British Gold PVD	86 P6 8093
Matt Copper PVD	86 P9 8093
Deep Black PVD	86 S1 8093
Pure Brass PVD	86 Q7 8093
Raw Metal PVD	86 Q8 8093

不锈钢拉丝 **86 93 8093**

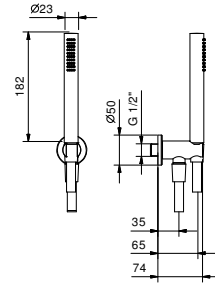

8116

整套淋浴

- FIT系列手持花洒
- 带手持花洒托架的取水栓
- 方形底块
- 150cm PVC软管
- 1/2" 寸入水管



铬色	86 02 8116
哑光黑	86 13 8116
哑光白色	86 29 8116
Matt Gun Metal PVD	86 P5 8116
Matt British Gold PVD	86 P6 8116
Matt Copper PVD	86 P9 8116
Deep Black PVD	86 S1 8116

不锈钢拉丝 **86 93 8116**

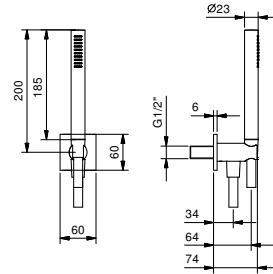

8021

整套淋浴

- 手持花洒SOHO系列
- 带手持花洒托架的取水栓
- 方形底块
- 150cm PVC软管
- 1/2" 寸入水管



铬色	86 02 8021
哑光黑	86 13 8021

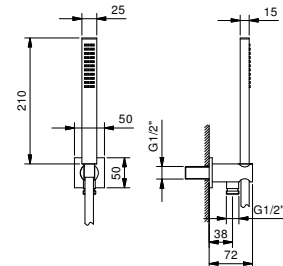

手持花洒

8068

整套淋浴

- FIT系列手持花洒
- 带手持花洒托架的取水栓
- 方形底块
- 150cm PVC软管
- 1/2" 寸入水管



铬色	86 02 8068
哑光黑	86 13 8068
Matt Gun Metal PVD	86 P5 8068
Matt British Gold PVD	86 P6 8068
Matt Copper PVD	86 P9 8068
Deep Black PVD	86 S1 8068

不锈钢拉丝 **86 93 8068**

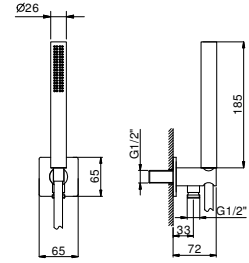

R043

整套淋浴

- ICONA系列手持花洒
- 带手持花洒托架的取水栓
- 圆形底座
- 150cm PVC软管
- 1/2" 寸入水管



铬色	53 02 R043
哑光黑	53 13 R043
Polished Nickel PVD	53 95 R043
Matt Gun Metal PVD	53 P5 R043
Matt British Gold PVD	53 P6 R043
Matt Copper PVD	53 P9 R043
Deep Black PVD	53 S1 R043
Pure Brass PVD	53 Q7 R043
Raw Metal PVD	53 Q8 R043

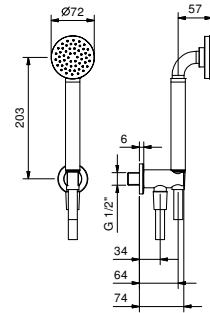

5943

整套淋浴

- VENEZIA系列手持花洒
- 带手持花洒托架的取水栓
- 圆形底座
- 150cm黄铜软管
- 140cm黄铜软管, PVD 选配
- 1/2" 寸入水管



铬色	29 02 5943
Polished Nickel PVD	29 95 5943
Matt Gun Metal PVD	29 P5 5943
Matt British Gold PVD	29 P6 5943
Matt Copper PVD	29 P9 5943
超金色	29 01 5943

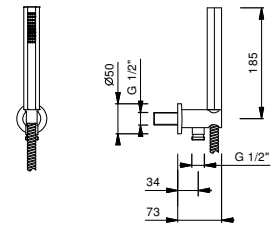

5944

整套淋浴

- FIT系列手持花洒
- 带手持花洒托架的取水栓
- 圆形底座
- 150cm黄铜软管
- 140cm黄铜软管, PVD 选配
- 1/2" 寸入水管



铬色	29 02 5944
Polished Nickel PVD	29 95 5944
Matt Gun Metal PVD	29 P5 5944
Matt British Gold PVD	29 P6 5944
Matt Copper PVD	29 P9 5944
超金色	29 01 5944

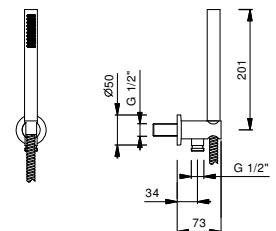

手持花洒

8144

整套淋浴

- FIT系列手持花洒
- 带手持花洒托架的取水栓
- 方形底块
- 150cm PVC软管
- 1/2" 寸入水管



Polished Nickel PVD 86 95 8144
Matt Gun Metal PVD 86 P5 8144

不锈钢拉丝 86 93 8144

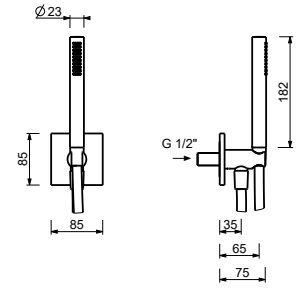

Z349

缸边龙头手持花洒套件

- SUN系列手持花洒
- 150cm 软管

注意：FIT 系列手持花洒 PVD 完成面



铬色 50 02 Z349
哑光黑 50 13 Z349
哑光白色 50 29 Z349
Matt Gun Metal PVD 50 P5 Z349
Matt British Gold PVD 50 P6 Z349
Matt Copper PVD 50 P9 Z349
Deep Black PVD 50 S1 Z349

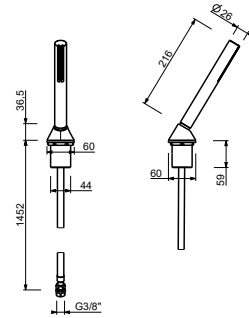

Z350

缸边龙头手持花洒套件

- ICONA系列手持花洒
- 150cm 软管



铬色 53 02 Z350
哑光黑 53 13 Z350
Polished Nickel PVD 53 95 Z350
Matt Gun Metal PVD 53 P5 Z350
Matt British Gold PVD 53 P6 Z350
Matt Copper PVD 53 P9 Z350
Deep Black PVD 53 S1 Z350
Pure Brass PVD 53 Q7 Z350
Raw Metal PVD 53 Q8 Z350

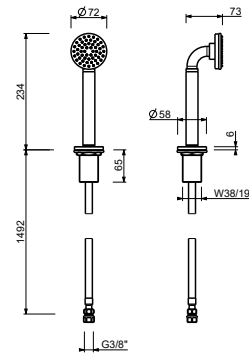

Z351

缸边龙头手持花洒套件

- FIT系列手持花洒
- 150cm 软管



Polished Nickel PVD 49 95 Z351
Matt Gun Metal PVD 49 P5 Z351

不锈钢拉丝 49 93 Z351

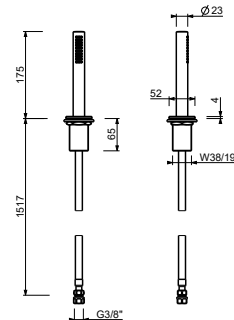

手持花洒

9673

手持花洒

- SUN系列
- 基材: ABS
- 流速限制器 9升/分钟
- 防钙化系统
- 止回阀

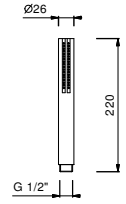

铬色	90 02 9673
哑光黑	90 13 9673
哑光白色	90 29 9673

8783

手持花洒

- FIT 系列
- 基材: 黄铜
- 基材: 不锈钢
- 流速限制器 9升/分钟
- 防钙化系统
- 止回阀

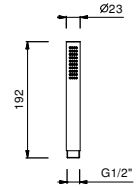

铬色	90 02 8783
哑光黑	90 13 8783
哑光白色	90 29 8783
Polished Nickel PVD	90 95 8783
Matt Gun Metal PVD	90 P5 8783
Matt British Gold PVD	90 P6 8783
Matt Copper PVD	90 P9 8783
Deep Black PVD	90 S1 8783
Pure Brass PVD	90 Q7 8783
Raw Metal PVD	90 Q8 8783
超金色	90 01 8783
红色	90 06 8783
不锈钢拉丝	90 93 8783

9418

手持花洒

- SOHO系列
- 流速限制器 9升/分钟
- 防钙化系统
- 止回阀

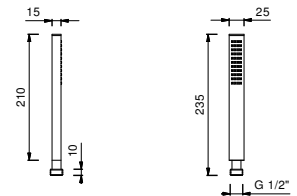

铬色	90 02 9418
哑光黑	90 13 9418

手持花洒

9849

手持花洒

- VENEZIA系列
- 流速限制器 9升/分钟
- 防钙化系统
- 止回阀



铬色	90 02 9849
Polished Nickel PVD	90 95 9849
Matt Gun Metal PVD	90 P5 9849
Matt British Gold PVD	90 P6 9849
Matt Copper PVD	90 P9 9849
超金色	90 01 9849

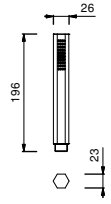

8914

手持花洒

- DISCO系列
- 基材：ABS
- 直径10cm
- 圆杆
- 流速限制器 9升/分钟
- 防钙化系统
- 止回阀



铬色	90 02 8914
----	------------

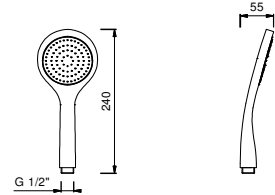

Z348

手持花洒

- DISCO系列
- 基材：ABS
- 直径11cm
- 三种喷雾方式:雨淋、强力喷射、按摩
- 流速限制器12升/分钟
- 防钙化系统
- 止回阀



铬色	90 02 Z348
哑光黑	90 13 Z348
Brushed Nickel PVD	90 92 Z348
Polished Nickel PVD	90 95 Z348
Matt Gun Metal PVD	90 P5 Z348
Matt British Gold PVD	90 P6 Z348
Matt Copper PVD	90 P9 Z348
Deep Black PVD	90 S1 Z348

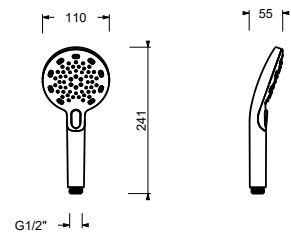

8929

手持花洒

- DISCO系列
- 基材：ABS
- 直径13cm
- 三种喷雾方式:雨淋、强力喷射、按摩
- 流速限制器12升/分钟
- 防钙化系统
- 止回阀



铬色	90 02 8929
哑光黑	90 13 8929
Brushed Nickel PVD	90 92 8929
Matt Gun Metal PVD	90 P5 8929
Matt British Gold PVD	90 P6 8929
Matt Copper PVD	90 P9 8929
Deep Black PVD	90 S1 8929

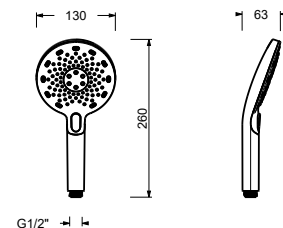

手持花洒

9890

手持花洒

- DISCO系列
- 基材: ABS
- 直径14cm
- 2种喷嘴: 72个雨淋喷嘴, 4个按摩喷嘴
- 流速限制器12升/分钟
- 防钙化系统
- 止回阀

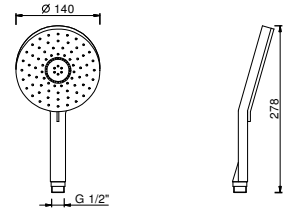

铬色

90 02 9890

8938

手持花洒

- ICONA
- 流速限制器 9升/分钟
- 防钙化系统
- 止回阀



- | | |
|-----------------------|------------|
| 铬色 | 90 02 8938 |
| 哑光黑 | 90 13 8938 |
| Polished Nickel PVD | 90 95 8938 |
| Matt Gun Metal PVD | 90 P5 8938 |
| Matt British Gold PVD | 90 P6 8938 |
| Matt Copper PVD | 90 P9 8938 |
| Deep Black PVD | 90 S1 8938 |
| Pure Brass PVD | 90 Q7 8938 |
| Raw Metal PVD | 90 Q8 8938 |

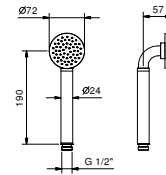

淋浴滑杆

8016

淋浴滑杆

- 长度90cm
- 不带取水栓
- 不带手持花洒
- 150cm PVC软管
- 可调节滑座

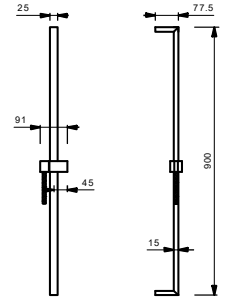

铬色 86 02 8016
 超金色 86 01 8016
 不锈钢拉丝 86 93 8016

8096

淋浴滑杆

- 长度87,5cm
- 不带取水栓
- 不带手持花洒
- 不带软管
- 可调节滑座

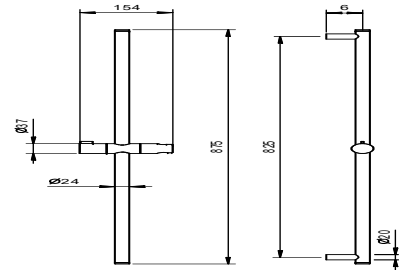

铬色 86 02 8096

8145

淋浴滑杆

- 长度60cm
- 150cm PVC软管
- 可调节滑座
- 不带取水栓
- 不带手持花洒

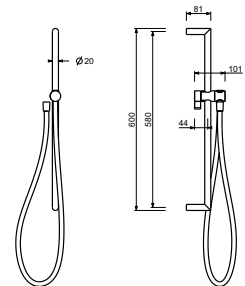

铬色 86 02 8145
 哑光黑 86 13 8145
 哑光白色 86 29 8145
 Polished Nickel PVD 86 95 8145
 Matt Gun Metal PVD 86 P5 8145
 Matt British Gold PVD 86 P6 8145
 Matt Copper PVD 86 P9 8145
 Deep Black PVD 86 S1 8145
 Pure Brass PVD 86 Q7 8145
 Raw Metal PVD 86 Q8 8145
 超金色 86 01 8145
 不锈钢拉丝 86 93 8145

淋浴滑杆

9247

淋浴滑杆

- 长度90cm
- 150cm PVC软管
- 可调节滑座
- 不带取水栓
- 不带手持花洒



铬色	86 02 9247
哑光黑	86 13 9247
哑光白色	86 29 9247
Polished Nickel PVD	86 95 9247
Matt Gun Metal PVD	86 P5 9247
Matt British Gold PVD	86 P6 9247
Matt Copper PVD	86 P9 9247
Deep Black PVD	86 S1 9247
超金色	86 01 9247

不锈钢拉丝 **86 93 9247**

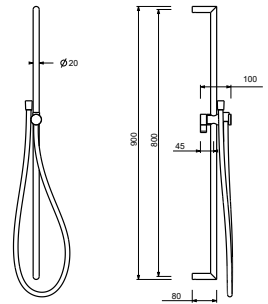

取水栓

9323

取水栓

- 圆形底座
- 基材：黄铜
- 手持花洒固定托架
- 软管通过锥形螺母连接



铬色	91 02 9323
哑光黑	91 13 9323
哑光白色	91 29 9323
Polished Nickel PVD	91 95 9323
Matt Gun Metal PVD	91 P5 9323
Matt British Gold PVD	91 P6 9323
Matt Copper PVD	91 P9 9323
Deep Black PVD	91 S1 9323
Pure Brass PVD	91 Q7 9323
Raw Metal PVD	91 Q8 9323

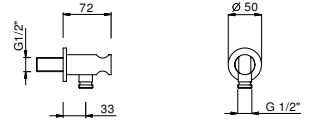

不锈钢拉丝 **91 93 9323**

9446

取水栓

- 方形底块
- 基材：黄铜
- 手持花洒固定托架
- 软管通过锥形螺母连接



铬色	91 02 9446
哑光黑	91 13 9446
Polished Nickel PVD	91 95 9446
Matt Gun Metal PVD	91 P5 9446
Matt British Gold PVD	91 P6 9446
Matt Copper PVD	91 P9 9446
Deep Black PVD	91 S1 9446
Pure Brass PVD	91 Q7 9446
Raw Metal PVD	91 Q8 9446

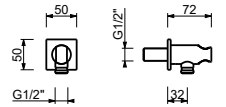

不锈钢拉丝 **91 93 9446**

7034

取水栓

- 圆形底座
- 基材：黄铜
- 不带手持花洒托架



铬色	91 02 7034
哑光黑	91 13 7034
哑光白色	91 29 7034
Polished Nickel PVD	91 95 7034
Matt Gun Metal PVD	91 P5 7034
Matt British Gold PVD	91 P6 7034
Matt Copper PVD	91 P9 7034
Deep Black PVD	91 S1 7034
Pure Brass PVD	91 Q7 7034
Raw Metal PVD	91 Q8 7034

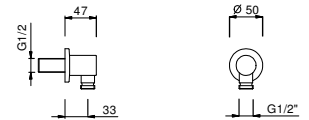

不锈钢拉丝 **91 93 7034**

9417

取水栓

- 方形底块
- 基材：黄铜
- 不带手持花洒托架



铬色	91 02 9417
哑光黑	91 13 9417
哑光白色	91 29 9417
Polished Nickel PVD	91 95 9417
Matt Gun Metal PVD	91 P5 9417
Matt British Gold PVD	91 P6 9417
Matt Copper PVD	91 P9 9417
Deep Black PVD	91 S1 9417
Pure Brass PVD	91 Q7 9417
Raw Metal PVD	91 Q8 9417

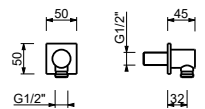

不锈钢拉丝 **91 93 9417**

软管

9349

软管

- 基材: PVC
- 长150cm
- 直径1/2英寸, 锥形螺母, 底宽1/2英寸



铬色	90 02 9349
哑光黑	90 13 9349
乳白色	90 26 9349
Polished Nickel PVD	90 95 9349
Matt Gun Metal PVD	90 P5 9349
Matt British Gold PVD	90 P6 9349
Matt Copper PVD	90 P9 9349
Deep Black PVD	90 S1 9349
Pure Brass PVD	90 Q7 9349
Raw Metal PVD	90 Q8 9349

不锈钢拉丝 90 93 9349

9193

软管

- 基材: 黄铜
- 150cm黄铜软管
- 140cm黄铜软管, PVD 选配
- 直径15mm
- 直径1/2英寸, 锥形螺母, 底宽1/2英寸



铬色	90 02 9193
哑光黑	90 13 9193
Matt Gun Metal PVD	90 P5 9193
Matt British Gold PVD	90 P6 9193
Matt Copper PVD	90 P9 9193
Deep Black PVD	90 S1 9193

9671

软管

- 基材: PVC
- 长200cm
- 直径1/2英寸, 锥形螺母, 底宽1/2英寸



铬色	90 02 9671
哑光黑	90 13 9671
乳白色	90 26 9671
Matt Gun Metal PVD	90 P5 9671
Matt British Gold PVD	90 P6 9671
Matt Copper PVD	90 P9 9671
Deep Black PVD	90 S1 9671
Pure Brass PVD	90 Q7 9671
Raw Metal PVD	90 Q8 9671

不锈钢拉丝 90 93 9671

1982

软管

- 基材: 黄铜
- 长150cm
- 1/2" conico x 3/8F



铬色	90 02 1982
----	------------

软管

9245

软管

- 基材：黄铜
- 长200cm
- 1/2" conico x 3/8F



铬色

90 02 9245

0819

软管

- 基材：黄铜
- 长150cm
- 直径15mm



红色
定制RAL颜色

90 06 0819

90 _ 0819

花洒托架

9129

手持花洒固定托架

- 软管通过锥形螺母连接
- 基材: ABS

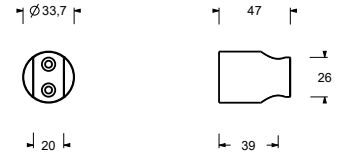

铬色	90 02 9129
哑光黑	90 13 9129
哑光白色	90 29 9129
不锈钢拉丝	90 93 9129

Q133

手持花洒固定托架

- 软管通过锥形螺母连接
- 基材: 黄铜

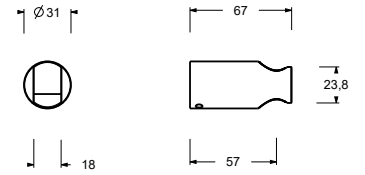

铬色	90 02 Q133
哑光黑	90 13 Q133
哑光白色	90 29 Q133
Matt Gun Metal PVD	90 P5 Q133
Matt British Gold PVD	90 P6 Q133
Matt Copper PVD	90 P9 Q133
Deep Black PVD	90 S1 Q133
Pure Brass PVD	90 Q7 Q133
Raw Metal PVD	90 Q8 Q133

0992

手持花洒固定托架

- 软管通过锥形螺母连接

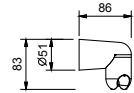

铬色	90 02 0992
----	------------

侧边身体喷雾

9248

侧边身体按摩喷雾

- 基材：黄铜
- 可调节方向
- 防钙化系统
- 1/2" 寸入水管



铬色	86 02 9248
哑光黑	86 13 9248
哑光白色	86 29 9248
Polished Nickel PVD	86 95 9248
Matt Gun Metal PVD	86 P5 9248
Matt British Gold PVD	86 P6 9248
Matt Copper PVD	86 P9 9248
Deep Black PVD	86 S1 9248
超金色	86 01 9248

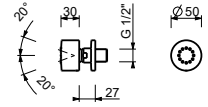

8024

侧边身体按摩喷雾

- 基材：黄铜
- 可调节方向
- 防钙化系统
- 1/2" 寸入水管



铬色	86 02 8024
哑光黑	86 13 8024
Matt Gun Metal PVD	86 P5 8024
Matt British Gold PVD	86 P6 8024
Matt Copper PVD	86 P9 8024
Deep Black PVD	86 S1 8024

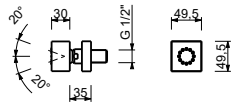

8055

侧边身体按摩喷雾

- 可调节方向
- 基材：ABS
- 防钙化系统
- 1/2" 寸入水管
- 包含预埋件部分



铬色	86 02 8055
----	------------

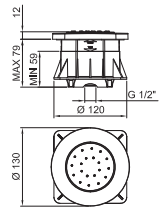

8056

侧边身体按摩喷雾

- 可调节方向
- 基材：ABS
- 防钙化系统
- 1/2" 寸入水管
- 包含预埋件部分



铬色	86 02 8056
----	------------

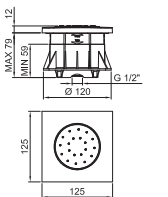

侧边身体喷雾

侧边身体按摩喷雾

- 基材：黄铜
- 基材：不锈钢
- 流速限制器 5升/分钟 3 bar
- 不可调节方向
- 防钙化系统
- 1/2" 寸入水管

8034B



外部组件

铬色	86 02 8034B
Polished Nickel PVD	86 95 8034B
Matt Gun Metal PVD	86 P5 8034B
Matt British Gold PVD	86 P6 8034B
Matt Copper PVD	86 P9 8034B
Deep Black PVD	86 S1 8034B
Pure Brass PVD	86 Q7 8034B
Raw Metal PVD	86 Q8 8034B

不锈钢拉丝

86 93 8034B

8034A



墙内预埋组件

86 00 8034A

